

Make Interface Board v1.0

The Make Interface Board provides easy access to all the available signals on the Make Controller Board in a small footprint. The peripherals (serial, twi, spi, can) are brought out to the edge of the board in groups for easy interfacing.

There are 15 free IO pins, and the pins for each of the peripherals can be used as general IO pins if they're not used as peripherals, offering a total of 35 IO pins + 4 dedicated analog inputs, in addition to Ethernet and USB.

Notes

The power supply in the middle of the board can be populated either with parts to make a switching supply, or a simple linear 3.3V regulator can be used. When using a regulator, be sure to use a 0.1 uF input capacitor and a 10 uF output capacitor.

Errata

- SPI channel 3 is marked as 'CS1' on the board...should be 'CS3'.

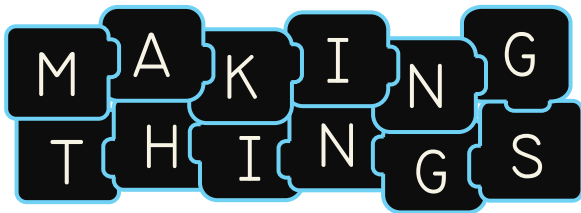

Make Interface Board v1.0

Dimensions & Mounting Holes

Actual Size
Dimensions in inches

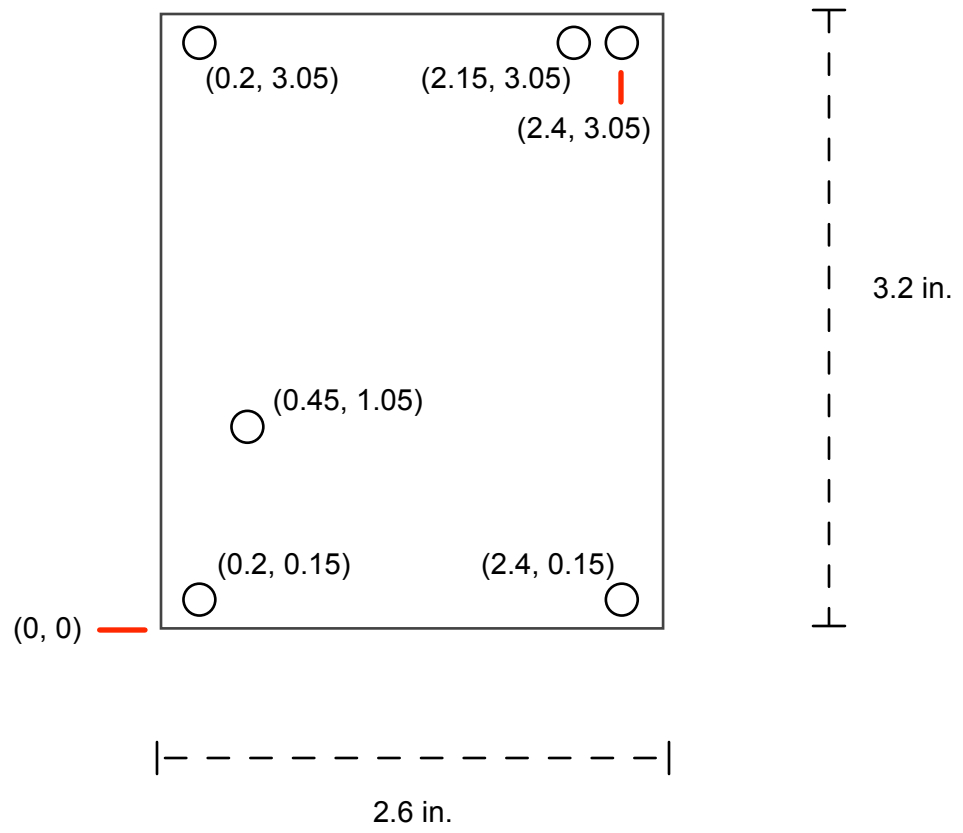

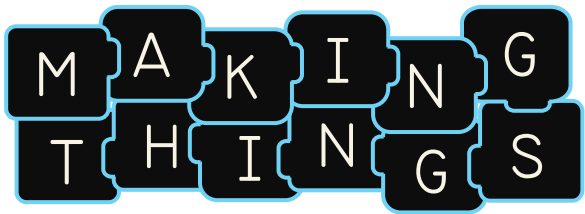

Make Interface Board v1.0

Underside Layout

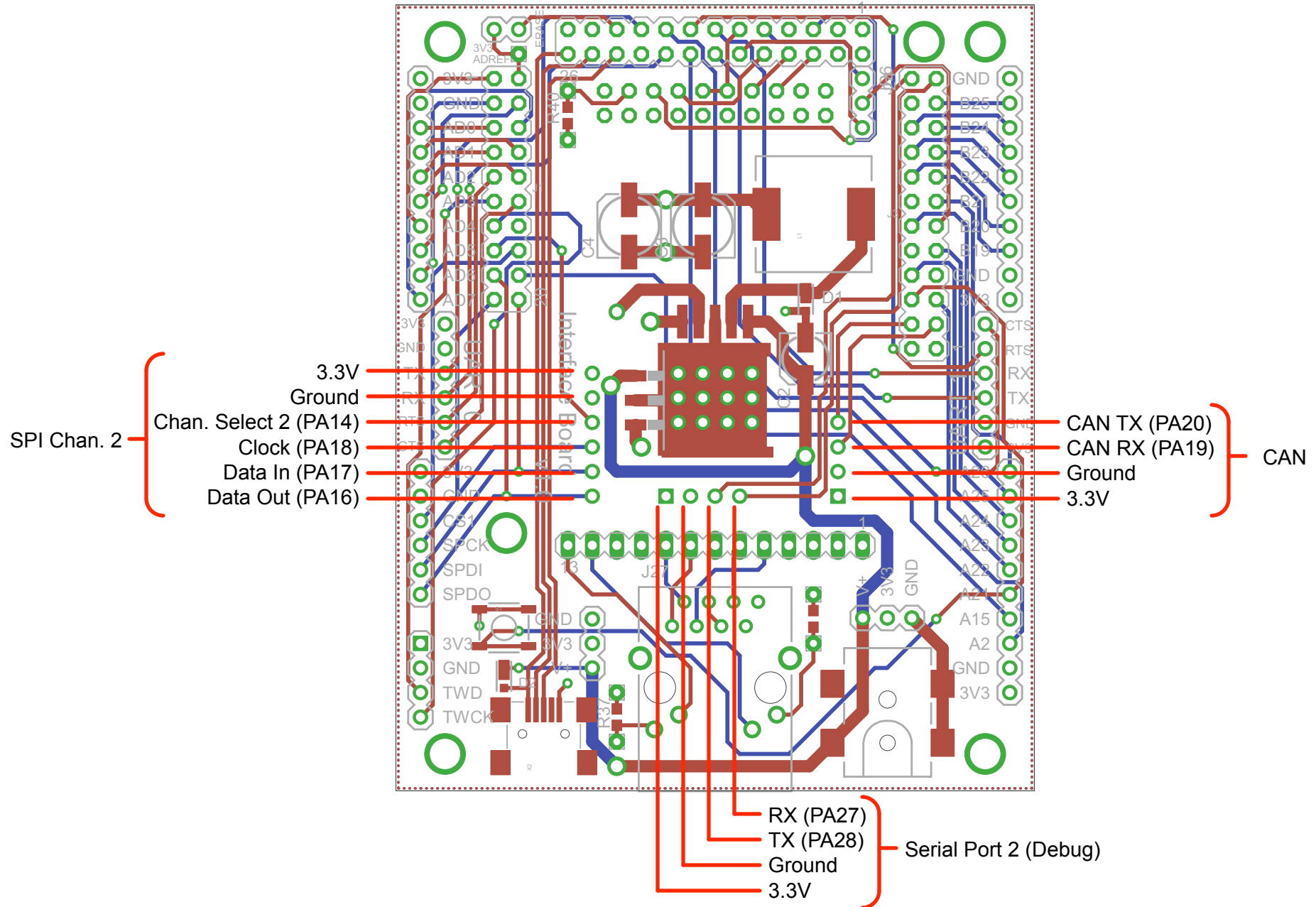

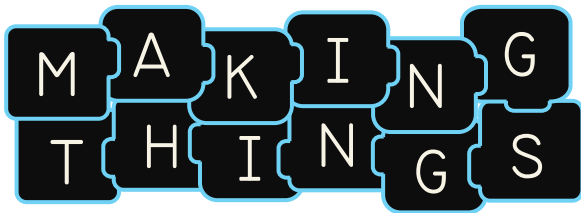

Make Interface Board v1.0

Topside Layout

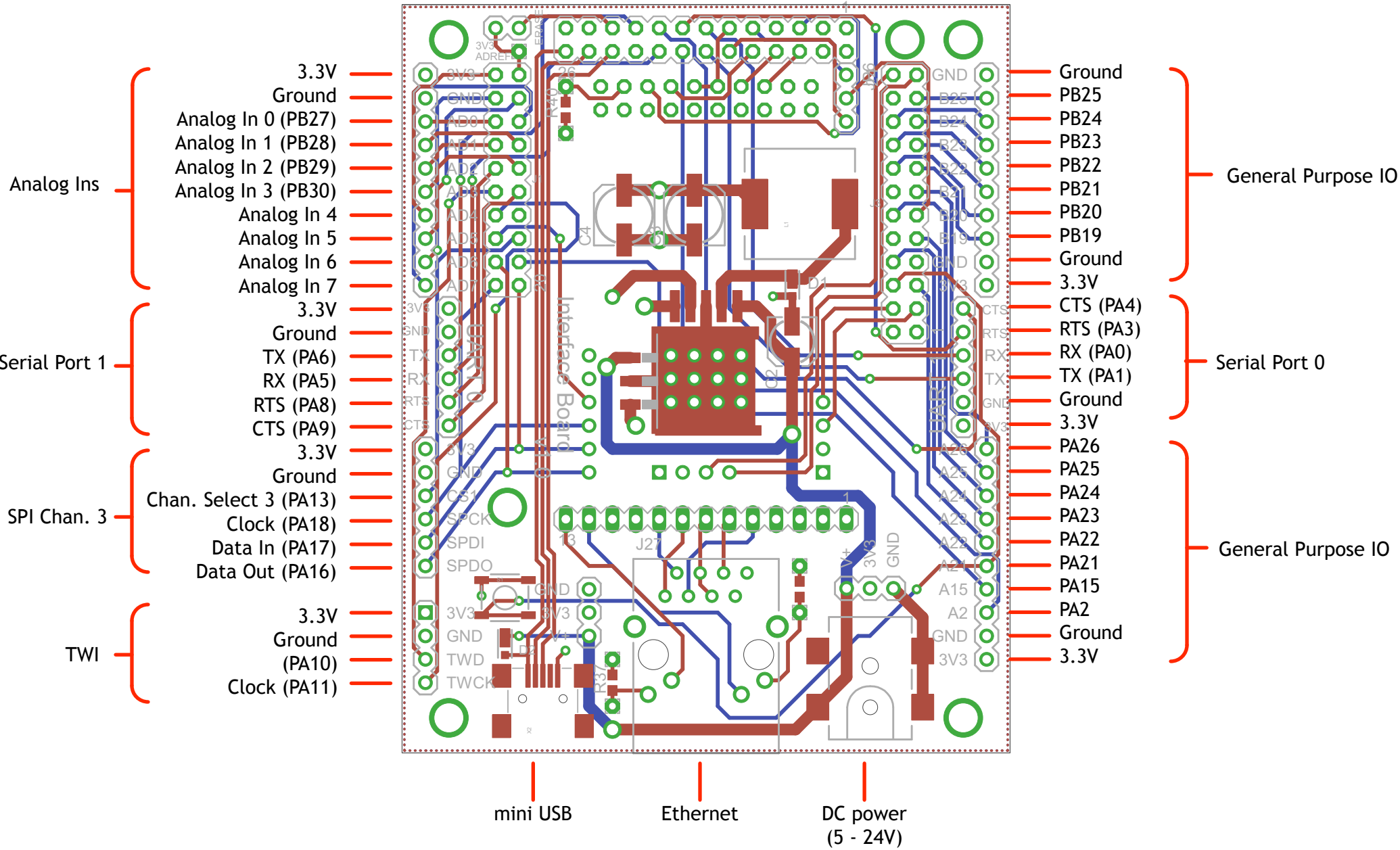

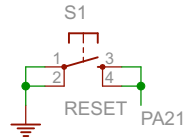
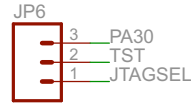
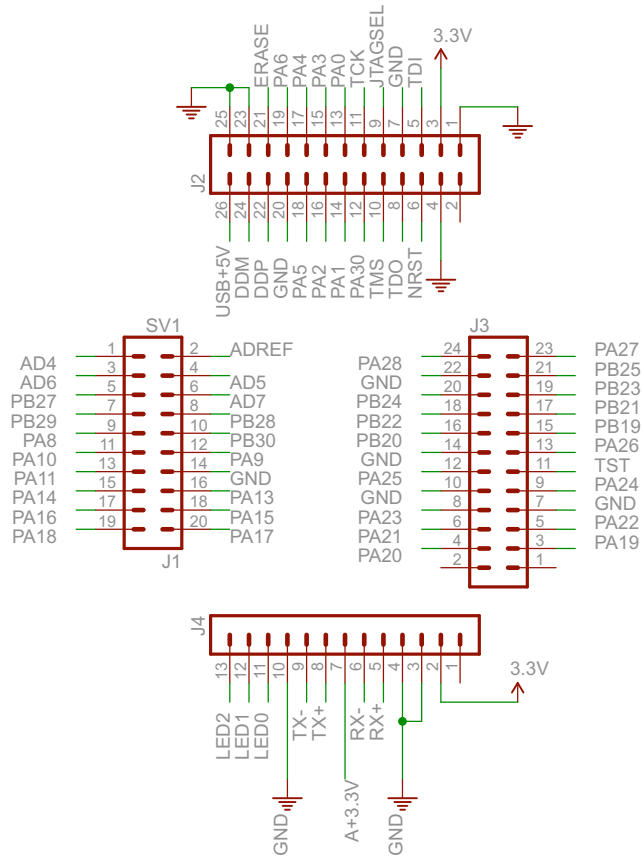

MAKE Interface Board

TITLE: interface_v10

Document Number:

REV:

Date: 2/10/2009 4:11:24 PM

Sheet: 1/3

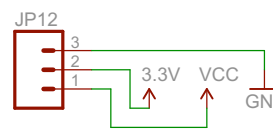
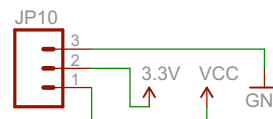
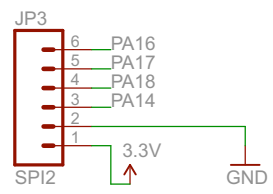
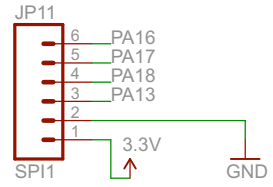
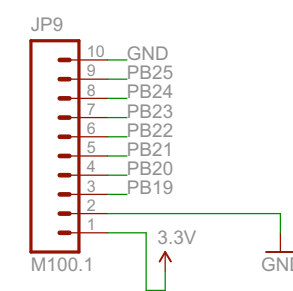
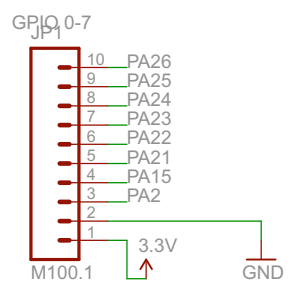
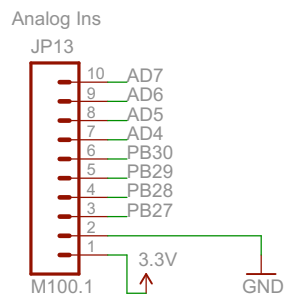
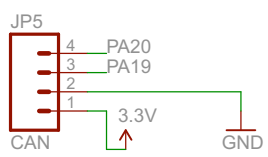
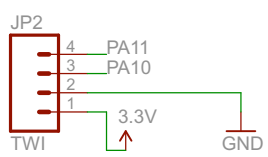
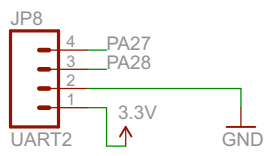
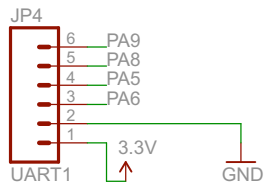
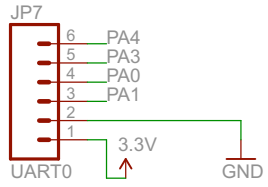

JTAG connector

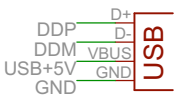
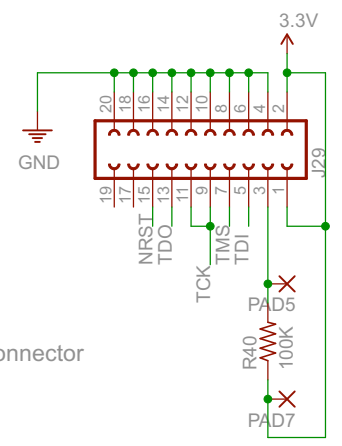

Ethernet connector

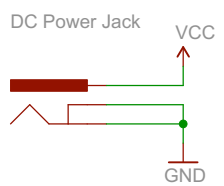
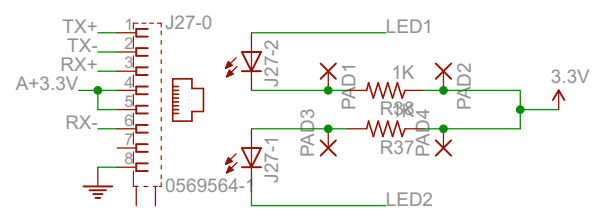

TITLE: interface_v10	
Document Number:	REV:
Date: 2/10/2009 4:11:24 PM	Sheet: 2/3

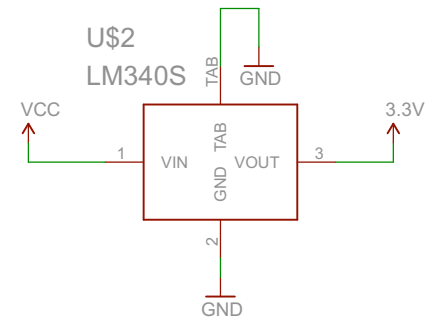
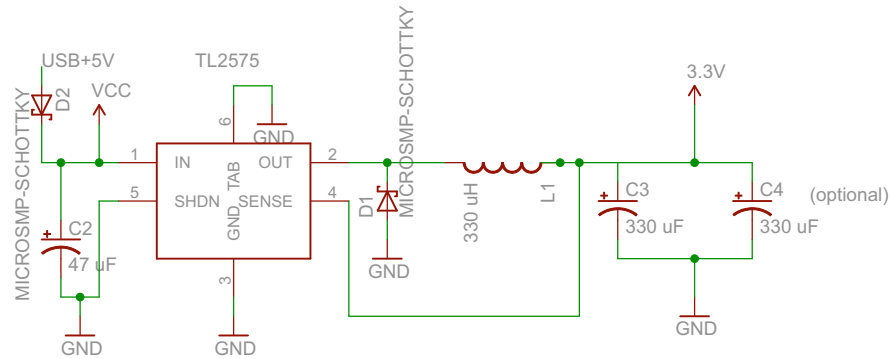

optional if not using switcher

Power Supply

TITLE: interface_v10

Document Number:

REV:

Date: 2/10/2009 4:11:24 PM

Sheet: 3/3